

PROJECT:	TYPE:
LOCATION:	CAT:



Description

The Step extrusion provides stair lighting along with two channels with rubber grip strips for anti-slip safety. The riser lighting feature can hold all Prizm tape light types excluding RGB+WW.

Features

- Extruded aluminum construction
- Includes rubber grip strips pre-installed in two slots on the top of the extrusion
- Use tape light, lens, end caps, and other accessories to create a complete fixture (tape light and accessories sold separately)

Mounting

The Step extrusion can be adhered to square edge steps and stairs with construction adhesive and/or screws. If using screws, remove the rubber grip strip and drill through the extrusion; use PE-STEP-TOOL to put the rubber grip strip back in place.

Applications

Step, stair, and other riser locations

Profile Dimensions

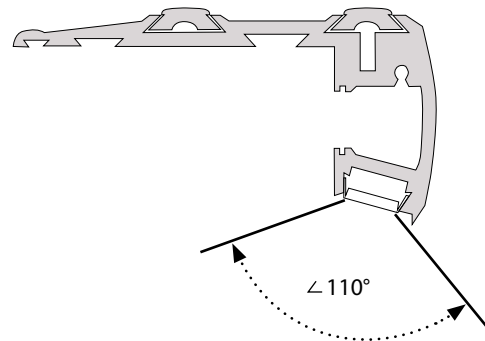
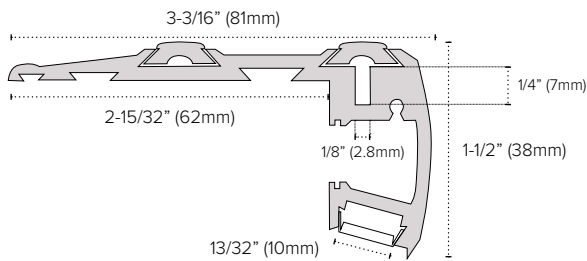

Ordering Information

Part Number	Description
PE-STEP-1M	Step Aluminum Extrusion
PE-UVLENS-1M	1 Meter Frosted Polycarbonate Lens For Step Extrusion; UV Resistant/Flame Retardant
PE-STEP-GRIP	Extra Rubber Grip Strip For Use In Step Extrusion
PE-STEP-RIGHT	Polypropylene Plastic End Cap For Right Side Of Step Extrusion
PE-STEP-LEFT	Polypropylene Plastic End Cap For Left Side Of Step Extrusion
PE-STEP-TOOL	Tool To Assist In Removing/Adding Rubberized Grip Strip

*Step extrusion is available as special order only.
For special orders, please contact us at: Quotes@PrizmLighting.com